

GP-Series

Pushbutton Switch



GP-Series pushbutton latch switches are designed for in-cab installation for on- and off-highway vehicles. Featuring an internal PCB rated to 0.25A 24VDC, this 2-position, snap-in panel-mounted switch is available with ON-OFF or Momentary ON-OFF circuitry. Configurable with or without a red LED backlight, the durable polycarbonate switch can be laser-etched in red with one of several standard icons to match your application.

1	0.25	24	IP54 Sealing
Pole	Amps	VDC	for Above-Panel Components

Typical Applications

• Truck • Bus • Construction • Mining • Agriculture

Tech Specs

Electrical

Contact Rating	Internal PCB rated to 0.25A @ 24VDC
Initial Contact Resistance	50.0 miliOhms MAX
Life	50,000 cycles
Terminals	Staked, Bright Acid Tin over Copper quick connect
Reverse Polarity	Reverse Polarity Test per SAE J1455 REV AUG2012, Section 4.11.3.3
Inrush	Cold Cranking & Jump Starting Capability Tests per SAE J1455 REV AUG2012, Section 4.11.3.3

Mechanical

Endurance	438,000 actuations
-----------	--------------------

Environmental

Environmental	IP54 for above panel components of the actual switch, representing an index of protection as applied to electrical equipment in accordance with ISO 20653
Operating Temperature	-40°C to +85°C
Vibration	SAE J1455 Random Vibration (22 Hours per Axis) SAE J1455 Swept Sine Vibration (5g)
Shock	MIL-STD-202G Method 213b, 30G - 11ms duration
Handling/Drop	Installation Harness Shock Test per SAE J1455 REV AUG2012, Section 4.11.3.3
Temperature Cycle	Thermal Cycle Test per SAE I455 Rev August 2012 Sec. 4.1.3.1 and Fig 2A
Thermal Shock	Test per SAE J1455 REV AUG2012 Sec 4.1.3.1, -40°C to +85°C
Moisture Resistance/ Humidity	SAE J1445 REV AUG2012 SEC. 4.2
Corrosion/Chemical Splash	SAE J1445 Rev AUG2012 Sec. 4.4; ISO 22241-1 Rec Oct2006
Dust	SAE J1455; Section 4.7; ISO 12103

Physical

Function	2 Position; Pushbutton Style
Operation	ON-OFF, and Momentary ON-OFF
Lighted	Right Angle SMD LED - rated to 100,000 hours 1/2 life
Seals	None
Mounting	Front Panel Push-In Acceptable Panel Thickness Range: .098 to .118 (2.50mm to 3.00mm) See Dimensional Specifications
Base	Nylon PA66 GF rated to UL94 HB
Actuator	Compound actuator structure molded of thermoplastic polycarbonate rated to UL94 V0 interlocked with a Nylon PA66 actuator rated to UL94 V2
Bracket	Acetal (Copolymer)
Laser Etched Pushbutton	Polycarbonate
Connector	Integrated female connector in switch base. Mates with Delphi Connector P/N 12064760, See circuit diagram for Pin Out.
Actuation Force	509-1019 gms (5-10N)
Movement	Vertical, max displacement: .256 [6.50] from OFF to maximum overtravel position .170 [4.32] from OFF to ON position
Weight	Approximately 1.2 ounces (34.47 g)

Ordering Scheme

Sample Part No. **GP 1 B C B - A R MV 1**

Selection 1 2 3 4 5 6 7 8 9

1. SERIES

GP Pushbutton Latch Switch

2. CIRCUIT

1 ON-OFF
2 (ON)-OFF

3. RATING

B .25A, 24VDC

4. BACKLIGHT COLOR

0 No LED
C Red

5. BRACKET COLOR

B Black

6. CAP COLOR/STYLE

A Black (Laser Etched)

7. LENS COLOR/STYLE

Z No Lens
R Red (Laser Etched)

8. LEGEND

00 No legend
MV Hazard Warning
For standard icons, see Standard Legends Code page.
For additional icons, please consult factory.

9. LEGEND ORIENTATION

0 No Legend
1 Orientation 1
2 Orientation 2
3 Orientation 3
4 Orientation 4

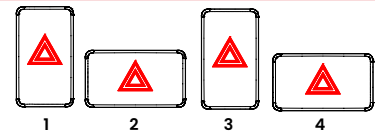

Notes:

1. "Tolerances For Image Size (Transfer or Laser) are +/- .020" Applicable on Field #7, Unless Otherwise Specified by customer".

[Configure Complete Part Number >](#)

Dimensional Specs

inches [millimeters]

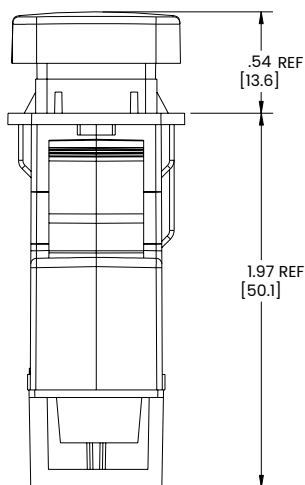
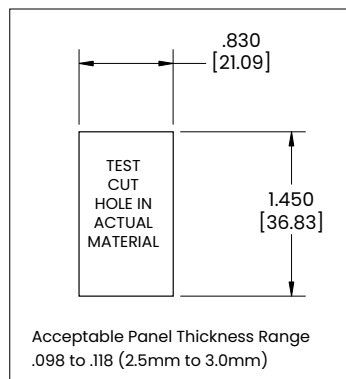
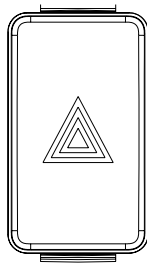

POS 1: "OFF"

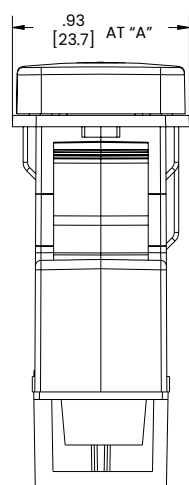

POS 2: "Max Overtravel"

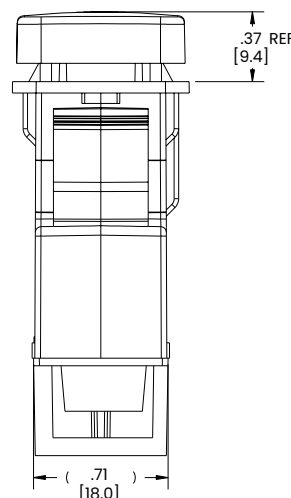

POS 3: "ON"

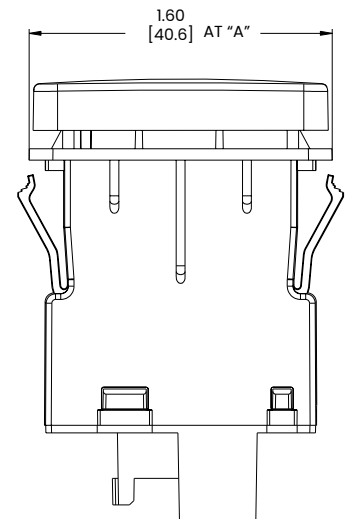

Circuit Diagram

"ON - OFF" CODE 1

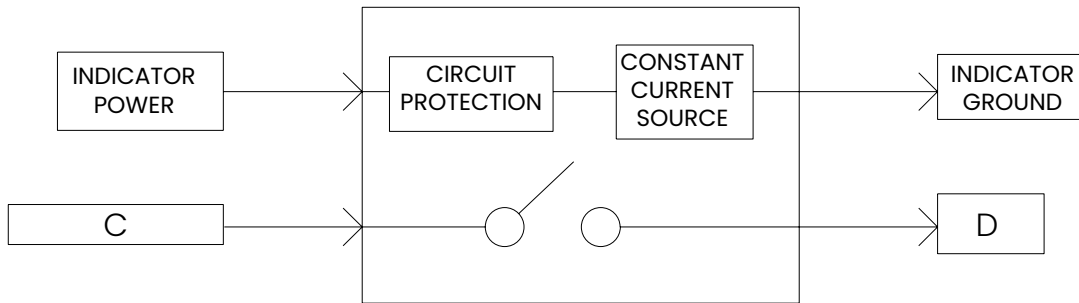

"(ON) - OFF" CODE 1

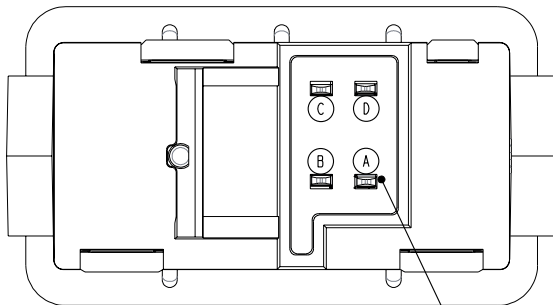
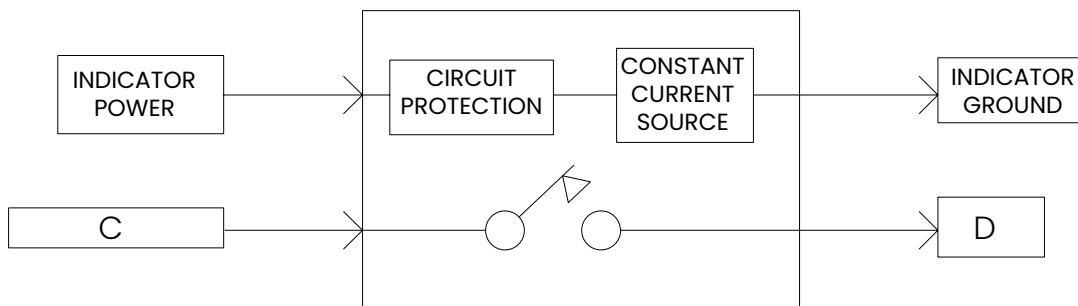

Table 2 Pin Outs	
PIN	Description
A	Indicator Ground
B	Indicator Power
C	---
D	---

SEE NOTE 1, TABLE 2

Notes:

1. Switch Mates with Delphi Connector P/N: 12064760 Terminal Plating: TIN

Standard Legend Codes

YK	UA	UB	US	UV	UW	UX	UY	MP	MR	PX	MS	MT
VU	MW	NZ	NX	NY	YM	VW	PS	PW	PZ	WG	WM	RN
			NAV LIGHTS	COURT LIGHTS	PANEL LIGHTS	ANCH LIGHTS	HEAD LIGHTS	FOG LIGHTS	DASH LIGHTS	DOCK LIGHTS	BEACON	LIGHT
RP	YG	TX	VD	VE	VF	VG	SH	SM	SN	SP	SR	SY
DIM	BRIGHT						BILGE PUMP	BILGE				
WY	WZ	UH	UJ	PD	PE	PF	VC	VJ	UF	UG	MU	TN
		WIPER										
NS	PB	SE	VZ	YE	NN	RW	PU	WA	YN	UE	NM	RJ
				ENG FAN	BLWR					HORN		
NR	YD	TL	VR	SL	VA	UC	VN	PK	VY	UZ	RH	NU
								UP	DOWN			
NV	RB	RC	RK	RL	MZ	RG	WS	WT	UD	UR	WD	TY
		WATER PUMP			ANCHOR							
PA	UK	WR	UU	UT	YR	PM	VV	WB	TB	TC	TD	TE
											ENG HATCH	ENG BRAKE
MY	PV	TA	TZ	WC	PT	PN	PH	RA	TU	TT	YL	SK
						TCS						
VS	UL	UM	WK	TS	VT	WL	VP	YJ	PJ	RY	UP	NW
NP	RE	RF	PP	PR	TV	PC	YT	YU	PL	WJ	MV	RR
		SEAT					CRUISE					
TK	RT	SZ	VX	WF	WH	PG	SJ	YA	YB	RM	TM	RD
RS	UN	TP	TR	NT	MX	YC	TW	TJ	YF	TH	TF	TG
		AUX	ON OFF	OFF ON	I O	O I	OFF ON	ON	OFF	I	O	II
YS	YH	SX	RZ	YP	WN	WP	WW	WX	SA	SB	SC	SD
RAISE	LOWER	HIGH	LOW	FWD	REV	DEPTH	TRIM TAB	ACC	NAV ANCH	WIND LASS UP/DN	LIVE WELL	REAR
ST	SU	WU	WV	SV	SW	VB	VH	VK	VL	VM	WE	SF
PARK	AUTO											
SG	SS	RU	RV	RX								